

The book was found

Zen Of Analog Circuit Design

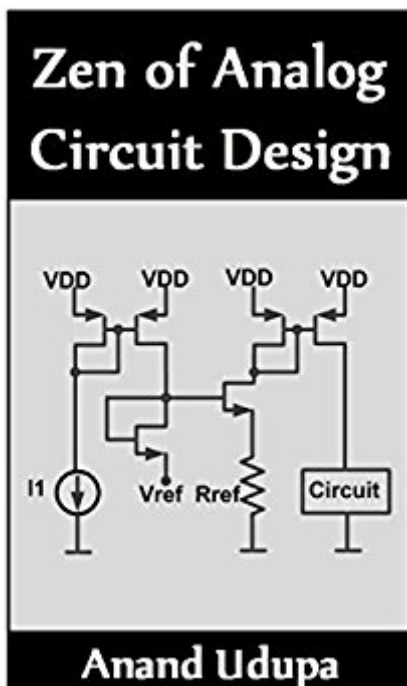

Synopsis

Zen of Analog Circuit Design RECENTLY UPDATED WITH NEW CONTENT From 2011 till 2013, I taught a course titled Analog Design for all which covered concepts starting with MOS transistors and progressed till the design of two-stage amplifiers. The course introduced concepts in a manner that led the student to the synthesis of new circuits, not merely their analysis. But I still felt that there was a more intuitive way to introduce Analog Circuit Design, one that would bring out the beauty of the subject so that the student could stop and smell the roses. But why a Zen of Analog? Because the foundational concepts in Analog closely mirror human relationships! The purpose of this book is to take a simplified and intuitive path to unlock some profound secrets of Analog. The protagonist of this book is Ang-Lao, a medieval monk who brings his insights into the Analog world to solve the challenges in human relationships. The book addresses a problem statement that much of Analog Circuit Design tries to solve - how do you realize an ideal buffer? It starts with the simple concepts of voltage sources and current sources. From the I-V curve of the MOS transistor, we see how it behaves much like a Voltage controlled current source (VCCS). The inherent challenge in getting even a simple two-transistor circuit to work is the conflict arising from having two such current source-like elements in series. The digital inverter is shown to be one such circuit that can function like an analog amplifier, albeit over a narrow range of input voltage. The effect of loading on such a circuit is illustrated graphically and is shown as an added challenge in getting it to work in an analog manner. Having understood the complications involved, we see how through the strikingly simple but immensely powerful concept of feedback, one of the two transistors can be modified subtly to make it behave like a voltage source. In that process, we realize our first approximation to an ideal analog buffer. We then see how manifestations of the same concept leads us to the synthesis of a whole bunch of two transistor circuits - source followers, common source amplifiers with gm-load and with diode-connected load, and differential amplifiers. The concepts used in synthesis of such elegant circuits are also extended to the analysis of much more complex circuits, for example, a Voltage to Current (V2I) conversion circuit. We introduce the concept of small signal parameters, g_m , g_{ds} , showing the calculations for the gain and output impedance of our circuits, and quantifying how good each of our buffers really are. The narrative switches between concepts of Electronics and the story of Aman-Ra, an engineer from Medieval Egypt. Struggling with his relationships, his guiding light is Ang-Lao, who teaches him the secret to happy relationships. For some, this book will signal the end of the fear of Analog. For others, it will be the start of a love story. Concepts covered

- Ideal & non-ideal sources
- Controlled sources
- Active characteristics of Voltage & Current sources

and passive elements
sol-V characteristics of a MOSFET
oMOS transistor as a Voltage controlled current source
oDigital inverter as Analog amplifier
oOperating point
oCommon source (CS) amplifier
oEffect of loading on a CS amplifier
oFeedback
oHow can you make a MOSFET behave like a voltage source?
oSynthesis of a CS amplifier with diode-connected load
oAnalysis of a V2I circuit including an introduction to current mirror
oSynthesis of CS amplifier with gm-load
oSynthesis of source follower circuit
oSmall signal parameters: gm, gds
oSmall-signal gain and output impedance
oSynthesis of a differential amplifier
oSynthesis of an Operational amplifier
oRealizing the buffer using the Operational Amplifier

Book Information

File Size: 5252 KB

Print Length: 156 pages

Publication Date: June 1, 2015

Sold by: Amazon Digital Services LLC

Language: English

ASIN: B00YQ6XTW0

Text-to-Speech: Enabled

X-Ray: Not Enabled

Word Wise: Not Enabled

Lending: Not Enabled

Enhanced Typesetting: Enabled

Best Sellers Rank: #65,046 Paid in Kindle Store (See Top 100 Paid in Kindle Store) #1

in Kindle Store > Kindle eBooks > Engineering & Transportation > Engineering > Electrical & Electronics > Electronics > Transistors #2 in Kindle Store > Kindle eBooks > Engineering & Transportation > Engineering > Electrical & Electronics > Transistors #4 in Books > Engineering & Transportation > Engineering > Electrical & Electronics > Electronics > Transistors

Customer Reviews

I used to know how transistors worked. I wouldn't want this to be my first introduction to them. I'm still looking for the pyramids on my data sheets.

An interesting twist but not super useful.

Great book for gaining an intuitive understanding of circuits. This has a very different (but welcome)

approach. Anyone that has had trouble in the past with understanding how IC chips work should check this book out.

Excellent reference book.

Nice book. Does use analogies related to personal relationships that may/may-not be required. However well worth reading it.

Very hard to navigate on Kindle but that kind of goes with any technical books. Content wise, nice primer.

Pretty amazing book. Very interesting way of looking at Analog Circuit design through simple stories and real psychological analogies. Thoroughly enjoyed it!

Not enough content to make it worth \$5.

[Download to continue reading...](#)

ZEN: Everything You Need to Know About Forming Zen Habits – A Practical Guide to Find Inner Peace, Practice Mindfulness & Learn Zen Meditation (Zen Buddhism, Zen Mastery, Zen for Beginners) Integrated circuit devices and components (Integrated-circuit technology, analog and logic circuit design, memory and display devices) Analog Circuit Design, Volume 2: Immersion in the Black Art of Analog Design Zen Buddhism: How Zen Buddhism Can Create A Life of Peace, Happiness and Inspiration (Zen Buddhism for Beginners, Zen, Zen Books) Zen: Beginner's Guide to Understanding & Practicing Zen Meditation to Become Present (Zen for Beginners, Zen Meditation, Zen Habits, Meditation for Beginners) Zen of Analog Circuit Design Zen: Zen For Beginners – The Ultimate Guide To Incorporating Zen Into Your Life – A Zen Buddhism Approach To Happiness And Inner Peace Zen: How to Practice Zen Everywhere in Your Daily Life (FREE Bonus Inside) (Zen Meditation, Zen for Beginners, Buddhism) Zen Flesh Zen Bones: A Collection of Zen and Pre-Zen Writings Zen and Zen Classics 1: From the Upanishads to Huineng (Zen & Zen Classics) Winter Circuit (Show Circuit Series -- Book 2) (The Show Circuit) Analog Circuit Design Volume Three: Design Note Collection CMOS Analog Circuit Design (The Oxford Series in Electrical and Computer Engineering) Analog Circuit Design: A Tutorial Guide to Applications and Solutions An Analog Electronics Companion: Basic Circuit Design for Engineers and Scientists Analog Integrated Circuit Design Analog Circuit Design Series Designing Amplifier

Circuits (Analog Circuit Design) Analog Methods for Computer-Aided Circuit Analysis and Diagnosis
(Electrical and Computer Engineering) Summer Circuit (Show Circuit Series -- Book 1)

[Contact Us](#)

[DMCA](#)

[Privacy](#)

[FAQ & Help](#)